

General information

Cavity

Type series: EB

Dimensions and sectional view

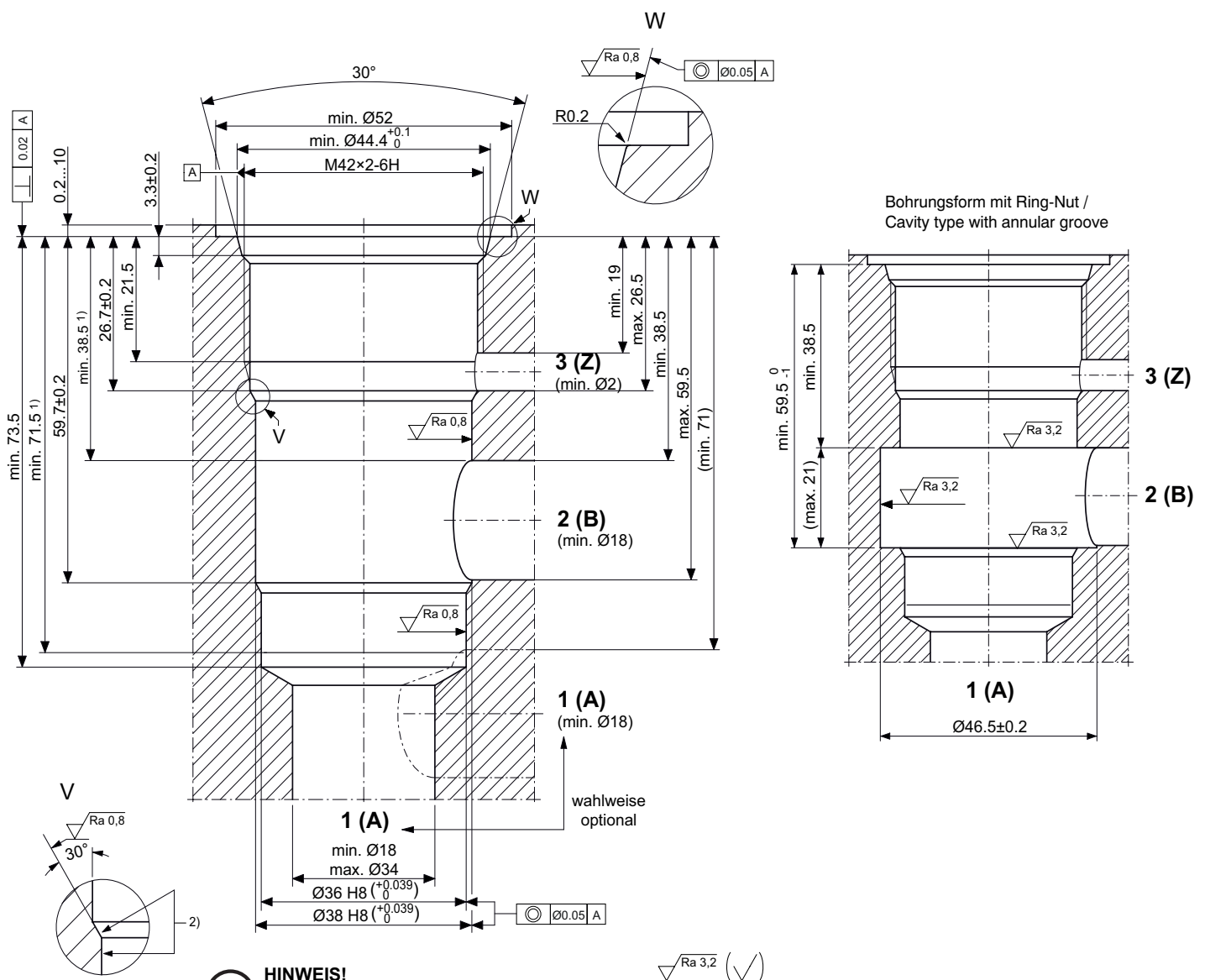

**HINWEIS!
NOTE!**

- 1) Passungstiefe
Minimum depth of specified diametral tolerance
- 2) Der Gewindeauslauf darf die Ringfläche und Ø38 H8 nicht verletzen.
The thread runout must not damage the ring surface or the Ø38 H8.

**Beispiel für die Masseinheit:
Example for the dimensional units:**
0.79 = 0.79 mm millimeter

Installation information

**ATTENTION!**

You must maintain the specified positional and diametral tolerances. To ensure trouble-free operation of the screw-in cartridges, we strongly recommend that pilot drilling, boring, reaming and cavity thread-cutting are always performed in one setup.

**ATTENTION!**

For improved Δp values with directional and logic valves, use the cavity with an annular groove in the 2 stage.

**NOTE!**

The cavity type EB complies with the standard according to ISO 7789: 42-06-0-07.

**NOTE!**

We offer form tool sets for sale or hire. For further information, see data sheet 400-P-040011.